



Instruction Manual

SLIM Tach® HS56 Magneto-resistive Encoder

Designed for use in
0.625-1.125" (16mm-30mm)
Hollow Shaft Applications



northstar
A Lake Shore Company

LIMITED WARRANTY

NorthStar Technologies, Inc. (henceforth NorthStar), the manufacturer, warrants this product for a period of twelve (12) months from the date of shipment. During the warranty period, under authorized return component parts to NorthStar freight prepaid, the company will repair, or at its option replace, any part found to be defective in material or workmanship, without charge to the Owner for parts, service labor, or associated customary shipping cost. Replacement or repaired parts will be warranted for only the unused portion of the original warranty.

This warranty is limited to NorthStar products purchased and installed in the United States. This same protection will extend to any subsequent owner during the warranty period. It does not apply to damage caused by accident, misuse, fire, flood or acts of God, or from failure to properly install, operate, or maintain the product in accordance with the printed instructions provided.

THIS WARRANTY IS IN LIEU OF ANY OTHER WARRANTIES, EXPRESSED OR IMPLIED, INCLUDING MERCHANTABILITY OR FITNESS FOR A PARTICULAR PURPOSE, WHICH ARE EXPRESSLY EXCLUDED. THE OWNER AGREES THAT NORTHSTAR'S LIABILITY WITH RESPECT TO THIS PRODUCT SHALL BE SET FORTH IN THIS WARRANTY, AND INCIDENTAL OR CONSEQUENTIAL DAMAGES ARE EXPRESSLY EXCLUDED.

WARRANTY RETURN POLICY

If you experience any technical problems with NorthStar products, please contact our Technical Support Department at (614) 891-2245 from 8:00 A.M. to 5:00 P.M. Eastern Standard Time (EST), Monday through Friday, or in writing to fax: (614) 891-6909, or email: service@northstar-tec.com. Please be ready to provide your customer number, item description, serial number, invoice number, date of purchase, and the specifics of the problem.

A representative will attempt to solve your problem over the telephone by running a few diagnostics. If it is determined by our representative in conjunction with the Customer that the product is required to be returned to NorthStar's factory for warranty repair, a Return Goods Authorization (RGA) number will be issued. For control purposes, only those items identified with an RGA number may be returned to NorthStar. Please make sure that the RGA number is clearly marked on the shipping label. Packages missing an RGA number cannot be accepted by our Receiving Department and must be returned to the sender freight COD. Ship returned products to NorthStar PRE-PAID and insured for its full value.

EXPRESS SERVICE IS OFFERED ON ALL WARRANTY REPAIRS WHERE AN RGA NUMBER HAS BEEN ISSUED. IF THE SAME WARRANTY PART THAT IS BEING RETURNED IS IN STOCK, NORTHSTAR WILL IMMEDIATELY SHIP OUT A NEW REPLACEMENT PART, INVOICE THE REPLACEMENT PART AND ISSUE A CREDIT INVOICE WHEN THE RGA NUMBER WARRANTY PART IS RECEIVED AT NORTHSTAR AND IS CONFIRMED TO BE A WARRANTY REPAIR. NORTHSTAR WILL EXPRESS SHIP THE PRODUCT PRE-PAID, USING THE SAME METHOD BY WHICH THE WARRANTY PART WAS SHIPPED TO NORTHSTAR, (i.e., IF THE RGA WARRANTY PART WAS SHIPPED OVERNIGHT, NORTHSTAR WILL SHIP IN THE SAME MANNER.)

There is a 15% restocking fee on all items returned for credit to NorthStar. This includes all items that are returned for exchange. All replacement parts must be purchased before they are sent out to the customer. If credit needs to be issued it will be issued upon the return of the product if the unit is in good condition.

TRADEMARK ACKNOWLEDGMENT

Many of the designations used by manufacturers and sellers to distinguish their products are claimed as trademarks. Where those designations appear in this manual and NorthStar was aware of a trademark claim, the designations have been printed in initial capital letters and the [™] or [®] symbol used.

SLIM Tach[®] is a trademark of NorthStar Technologies, Inc.

Copyright © 1998 by NorthStar Technologies, Inc. All rights reserved. No portion of this manual may be reproduced, stored in a retrieval system, or transmitted, in any form or by any means, electronic, mechanical, photocopying, recording, or otherwise, without the express written permission of NorthStar.

Table of Contents

Chapter/Paragraph/Illustration	Page
1 Introduction.....	4
1.0 Safety Summary	4
1.2 General.....	5
1.3 Description.....	5
<i>Figure 1: Customer Outline Reference Dimensions</i>	<i>5</i>
1.4 Specifications.....	6
2 Installation.....	7
2.0 Inspection and Unpacking.....	7
2.1 Mounting the HS56 to a C-Face Motor.....	7
<i>Figure 2: HS56 Anti Rotation Turnbuckle (Motor C-Face Mounting).....</i>	<i>7</i>
2.2 Mounting the HS56 to a Motor with a Fan Shroud	8
<i>Figure 3: HS56 Anti Rotation Turnbuckle (Fan Shroud Mounting).....</i>	<i>8</i>
<i>Figure 4: HS56 Anti Rotation Turnbuckle (Motor with Fan Shroud)</i>	<i>8</i>
2.3 Electrical Installation	9
2.3.1 Quick Release Connector Hood Wiring	9
<i>Figure 5: Sealed Industrial Latching Connector.....</i>	<i>10</i>
2.4 Returning Equipment to NorthStar.....	10

Methods and apparatus disclosed and described herein have been developed solely on company funds of NorthStar Technologies, Inc. No government or other contractual support or relationship whatsoever has existed which in any way affects or mitigates proprietary rights of NorthStar Technologies, Inc. in these developments. Methods and apparatus disclosed herein may be subject to U.S. Patents existing or applied for. NorthStar Technologies, Inc. reserves the right to add, improve, modify, or withdraw functions, design modifications, or products at any time without notice. NorthStar shall not be liable for errors contained herein or for incidental or consequential damages in connection with furnishing, performance, or use of this material.

CHAPTER 1 INTRODUCTION

1.0 Safety Summary

High current, voltage, and rotating parts can cause serious or fatal injury. The use of electric machinery, like all other uses of concentrated power and rotating equipment, may be hazardous. Installing, operating, and maintaining electric machinery should be performed by qualified personnel, in accordance with applicable provisions of the National Electrical Code and sound local practices. Failure to comply with these precautions or with specific warnings elsewhere in this manual violates safety standards of design, manufacture, and intended use of the instrument. NorthStar Technologies, Inc. assumes no liability for the customer's failure to comply with these requirements.

Rotating Machinery

Avoid contact with rotating parts. Avoid by-passing or rendering inoperative any safety guards or protection devices. Avoid extended exposure in close proximity to machinery with high noise levels. Use proper care and procedures in handling, lifting, installing, operating and maintaining the equipment.

Before Installation

Safe maintenance practices with qualified personnel is imperative. Before starting maintenance procedures, be positive that, (1) equipment connected to the shaft will not cause mechanical rotation, (2) main machine windings have been disconnected and secured from all electrical power sources, and (3) all accessory devices associates with the work area have been de-energized. If high potential insulation test is required, follow procedures and precautions outlined in NEMA standards MG-1.

Grounding

Improperly grounding the frame of the machine can cause serious or fatal injury to personnel. Grounding of the machine frame and structure should comply with the National Electrical Code and with sound local practices. Check wiring diagram before connecting power.

Do Not Operate In An Explosive Atmosphere

Do not operate the instrument in the presence of flammable gases or fumes. Operating any electrical instrument in such an environment constitutes a definite safety hazard.

Keep Away From Live Circuits

Operating personnel must not remove instrument covers. Component replacement and internal adjustments must be made by qualified maintenance personnel. Do not replace components with power cable connected. To avoid injuries, always disconnect power and discharge circuits before touching them.

Do Not Substitute Parts Or Modify Instrument

Do not install substitute parts or perform any unauthorized modification to the instrument. Introducing additional hazards is dangerous. Return the instrument to an authorized NorthStar Technologies, Inc. representative for service and repair to ensure that safety features are maintained.

Dangerous Procedure Cautions

A CAUTION heading precedes potentially dangerous procedures throughout this manual. Instructions in the warnings *must* be followed.

1.2 General

These instructions do not claim to cover all details of variation in equipment or to provide for every possible contingency or hazard to be met in connection with installation, operation, and service. Should further information be desired or should particular problems arise which are not covered sufficiently for the purchaser's purposes, please contact NorthStar Technologies, Inc., or one of its designated representatives.

1.3 Description

The SLIM Tach[®] HS56 is a high performance, reliable digital tachometer, designed to provide position and velocity feedback from both AC and DC electric motors. The hollow shaft design allows ease of mounting on motors without accessory mounting flanges. Simply slide the HS56 onto the shaft, attach the anti-rotation arm to the motor, and tighten down the set screws that hold the unit onto the shaft. All of the critical alignments are already done for you in the encoder. The anti-rotation arm is very forgiving to any axial or radial motions that the motor might have, yet is very torsionally non-compliant.

Similar to NorthStar's heavy duty and mill duty encoders, the SLIM Tach[®] HS56 contains patented magneto-resistive technology. Magneto-resistive technology allows the NorthStar HS56 to be placed in the toughest environments. The unit is resistant to grease, oil, water, and dirt, making the HS56 the most rugged hollow shaft encoder on the market today. Operating voltages for the HS56 are 5-15 volts DC, and the electronics feature short circuit protection, reverse polarity protection, heavy duty line drivers, and EMI noise resistance. NorthStar provides a heavy duty, water-tight mating Industrial connector. The connector also features 1/2 inch NPT pipe thread for armored electrical conduit. The oversized, heavy duty bearings used in this unit are sealed and lubricated for life.

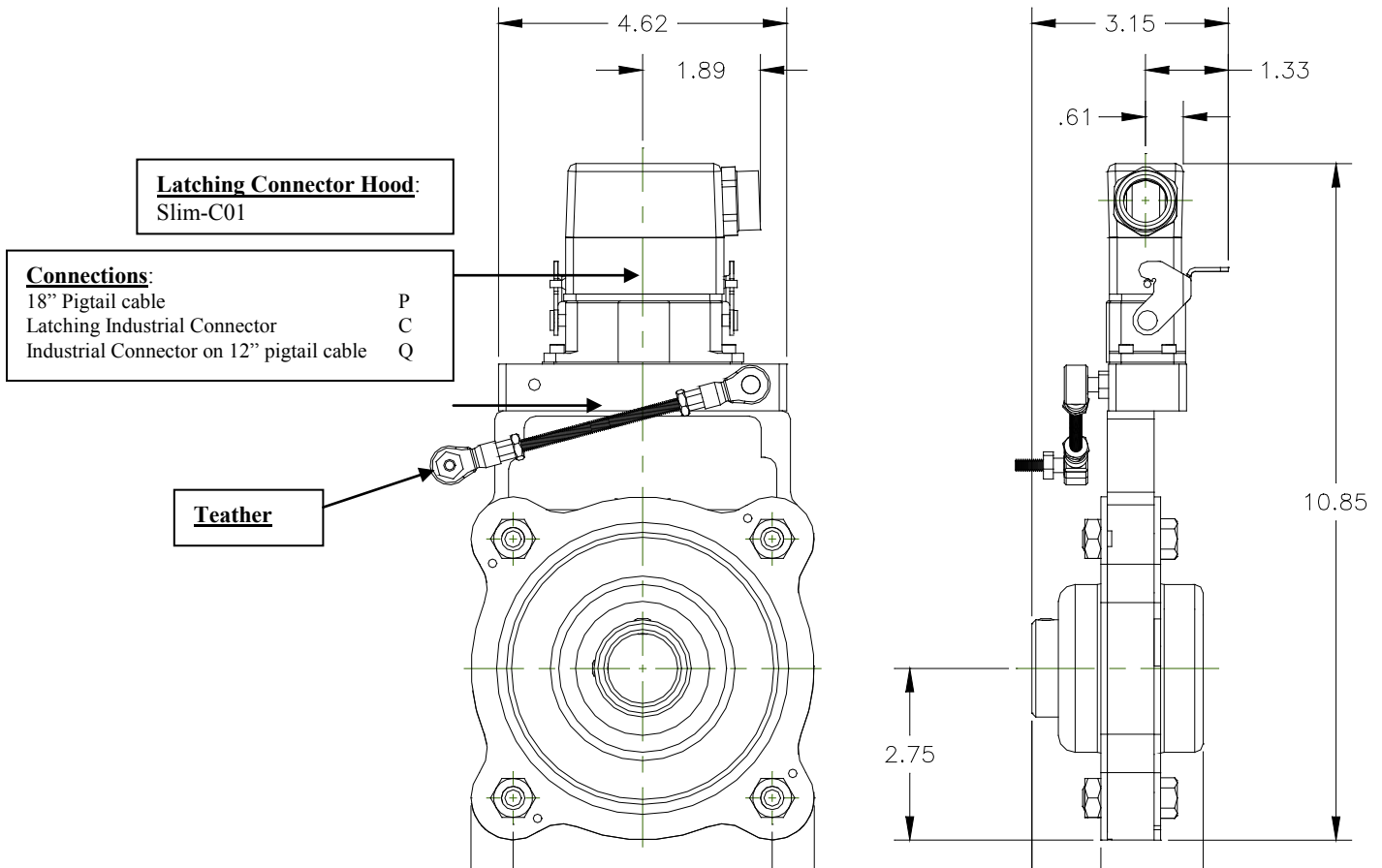

Figure 1: HS56 Customer Outline Reference Dimensions

1.3 Specifications

Electrical Specifications	
Resolution	512, 512Z, 1024, 1024Z, 2048 PPR
Frequency Response	0 – 120 KHz
Pulse Code	Incremental, Marker, Quadrature, Complements
Output Channels	A & B (incremental); Z (marker), A, B
Duty Cycle	50 ± 15% (within defined mechanical specs)
Quadrature Accuracy	A-B 90 ± 22°
Output Type	High Speed, Differential Driver
Rise and Fall Time	Less than 500ns @ 10,000 pf typical
Current Consumption	40 mA typical plus line driver load
ESD Protection	2kV
Output Current Capability	150 mA typical [350 mA maximum (worst case)]
Connector	10 pin Epic style, NEMA 4, 12 industrial connector
Suggested Cable	22 AWG, 8 Conductor, 18" length, 4 twisted shield pairs
Input Voltage	+ 5.0 to +15.0 VDC
Mechanical Specifications	
Maximum Operational Speed	3,600 RPM
Shaft Requirements	0.625-1.125" (+0.000, -0.0005)
Bearings	Sealed
Max Radial Runout	0.015" total indicated run out
Max Axial Travel	±0.150"
Box Weight	7 1/2lbs. (3.4 Kg)
Box Dimensions	8.75" x 14.25" x 4"
Environmental Specifications	
Operational Temperature	-20° to +80° C
Operational Humidity Capability	Maximum of 90%
Chemical Resistance	Salt spray, most solvents, mild acids and bases
Vibration	Maximum 15 g's RMS, 5-2000 Hz

Specifications subject to change without notice.

CHAPTER 2 INSTALLATION

2.0 Inspection and Unpacking

Inspect shipping container for external damage. All claims for damage (apparent or concealed) or partial loss of shipment must be made in writing to NorthStar within (5) days from receipt of goods. If damage or loss is apparent, please notify the shipping agent immediately.

Open shipping container and locate the packing list. The packing list is included to verify that all components, accessories, and manual were received. Please use the packing list to check off each item as the unit is unpacked. Inspect for damage. NorthStar recommends that the shipping container be retained for future shipping, storage, or return to factory purposes.

If any equipment was damaged in transit, be sure to file proper claims promptly with the carrier and insurance company. Please advise NorthStar Technologies of such filing. In case of parts shortages, advise NorthStar immediately. NorthStar cannot be responsible for any missing parts unless notified within 60 days of shipment. The standard NorthStar Technologies, Inc. warranty is included on page 2 of this manual.

2.1 Mounting the HS56 to a NEMA 180 or 56 C-Face Motor

1. When the HS56 is to be mounted onto a motor with opposite end NEMA C-Face, insert the appropriate bolt (i.e. 3/8"-16 UNC or 1/2"-13 UNC) (provided in hardware kit) into threaded hole on motor C-Face and tighten (see Figure 2). After positioning the encoder to the best angular orientation, adjust rod arm length (see Figure 2) and cut if necessary for proper fit. Align rod end turnbuckle assembly with bolt and tighten to 49 in-lbs. The HS56 anti-rotation arm assembly is designed to accommodate 4.5" and 8.5" C-Face mounting holes.
2. Slide the HS56 onto the motor shaft or stub shaft.
3. Attach the remaining end of the anti-rotation arm to the mounting bolt. Add a removable threaded locker and tighten the turnbuckle locking nuts.
4. Tighten the set screws holding the encoder on the shaft with the hex wrench provided.

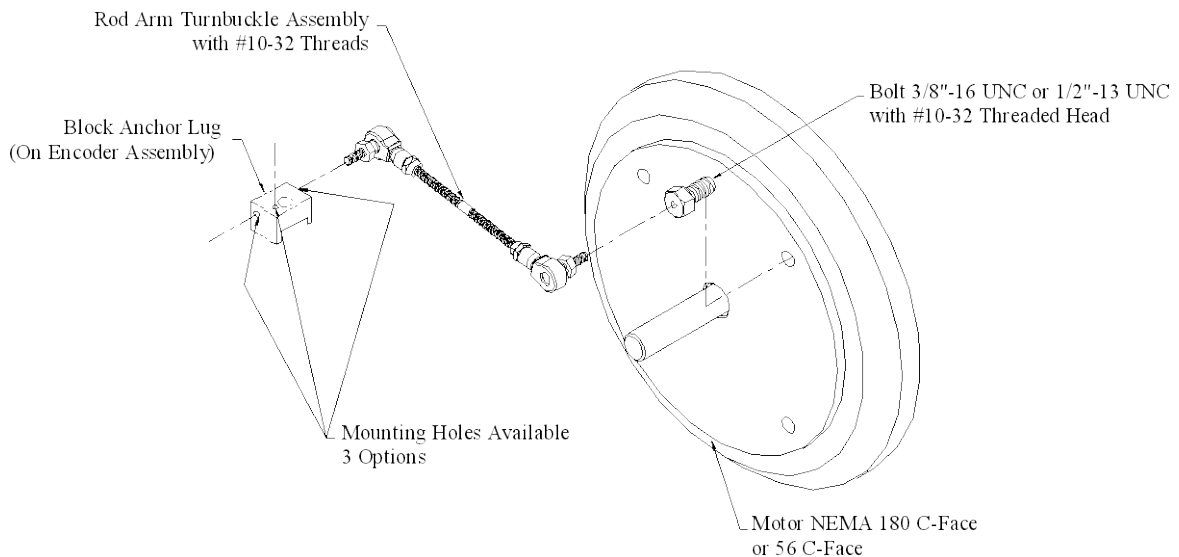

Figure 2: HS56 Anti Rotation Turnbuckle (Motor C-Face Mounting)

2.2 Mounting the HS56 to a Motor with a Fan Shroud

If the motor has only a fan shroud on the opposite drive end of the motor, use the mounting bolts on the end of the anti-rotation arm to mount the HS56 to the fan shroud. Figure 3 shows the anti-rotation arm attached to the fan shroud.

1. Arrange the anchor T-bolt as shown in Figure 4. Slide the anchor bolt into the fan shroud through an available vent.
2. Rotate the T-bolt 90° so the bolt catches the inside of the fan shroud.
3. With the anchor T-bolt positioned in the fan shroud, place ¼" washer over the bolt, tighten the hex standoff.
4. Insert anti-rotation rod end into the Hex standoff and tighten.

CAUTION!

The anchor bolt is designed for minimum ¼ inch of clearance between the fan and the fan shroud. If there is not ¼ clearance the fan may hit the anchor bolt head on the inside of the fan shroud. See drawing below. The minimum shaft length for fan shroud mounting is 2.65".

5. Slide the HS56 onto the accessory shaft.
6. With normal torque, tighten the set screws holding the encoder on the accessory shaft. The anti-rotation arm should be parallel with the encoder and perpendicular to the shaft. (For best holding performance, dimple or file a small flat on the shaft under the set screw.)

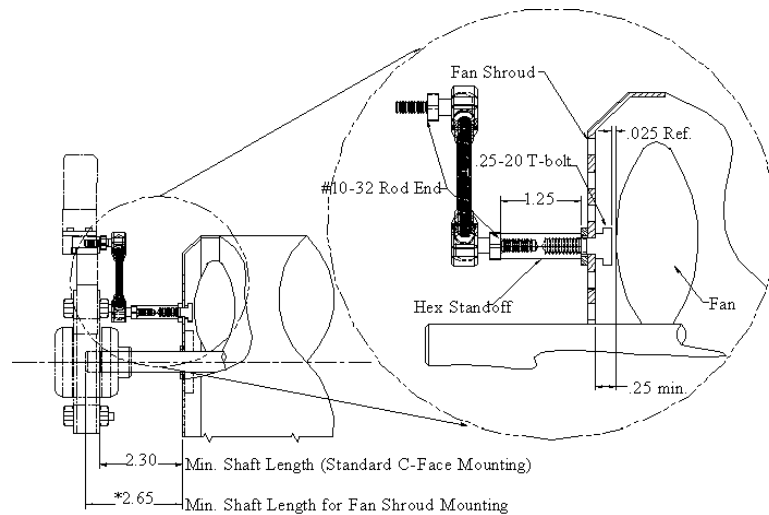

Figure 3: HS56 Anti Rotation Turnbuckle (Fan Shroud Mounting)

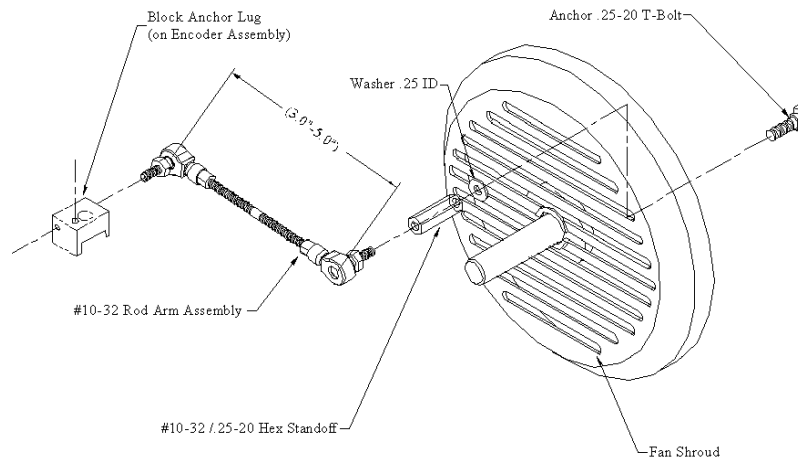

Figure 4: HS56 Anti Rotation Turnbuckle (Motor with Fan Shroud)

2.3 Electrical Installation

Electrical connections are made to the sensor module through a standard 1/2 inch NPT liquid tight flexible conduit. The nipple length may be changed to extend the outlet box if desired. Interconnection cable recommendations are as follows: stranded copper, 22 through 16 gage, braided or foil with drain wire shielding 0.05 μF maximum total mutual or direct capacitance, outer sheath insulated. Shrink tubing may be placed over any wires without insulation. For lengths over 100 feet, use 18 gage or larger, to a maximum of 1000 feet. If shielded twisted pair wire is used, do not cross channels. Keep each pair of complementary channel outputs together in a single twisted pair (e.g., A and A complement).

CAUTION!

Reversing power and common will not damage the unit. However, applying power to any of the sensor outputs may cause damage.

Table 1. Signal Coding Table

Signal	Connector Pin	Pigtail Cable	MS 3102E18-IT#
Common	1	Black	F
B	2	Green	B
A	3	Blue	A
Z *	4	Violet	C
No Connection	5	----	E
Vcc (5-15 VDC)	6	Red	D
/B	7	Yellow	I
/A	8	Gray	H
/Z *	9	Orange	J
Shield	10	Braid	G

* Applies only to units with index pulse capability.
 # Pinouts are for the sensors with the MS 3102E18IT connector

NOTE

The shield in the sensor module is isolated from the frame of the encoder. For maximum noise immunity, the shield wire or pin should be connected to the shield of the cable and that of the drive or other receiving device.

2.3.1 Quick Release Connector Hood Wiring

To install the Quick Release Connector, perform the following steps.

1. Remove the four screws from the mating connector housing that hold the terminal block in place. Remove terminal block from housing.
2. Insert wiring through liquid tight flexible seal and mating connector housing. Leave enough wire exposed to comfortably reach the terminal block. Wire to terminal block according to wire code in Table 1. A similar wiring list is attached to enclosure.

NOTE

There are two orientations of the connector hood. The terminal block can be inserted either way so the connector hood points up or down. Choose the direction best for your application.

4. Tighten Liquid Tight fitting on housing. **OPTIONAL:** In some hostile environments, seal between connector body and Sensor Module can be improved by smearing a sealant (silicone grease, etc.) on the neoprene seal of the connector.
5. Mate connector into place on sensor mount and snap the two latches into place. If only one sensor is being installed, ensure cover plate is installed over other sensor hole.

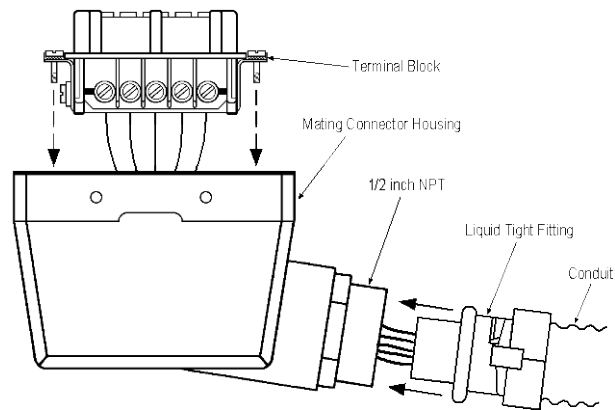

Figure 5: Sealed Industrial Latching Connector

2.4 Returning Equipment to NorthStar

If it is necessary to return the unit for repair or replacement, a Return Goods Authorization (RGA) number must be obtained from a factory representative before returning the equipment to our service department. When returning an instrument for service, the following information must be provided before NorthStar can attempt any repair.

1. Instrument model and serial number
2. User's name, company, address, and phone number
3. Malfunction symptoms
4. Description of system
5. Returned Goods Authorization number

Consult the factory for shipping instructions.



northstar